

Intragenerational stability of postmaterialism in Germany, the Netherlands and the United States

Authors	de Graaf,N.D.; Hagedaars,J.A.P.; Luijkx,R.
Published in	European Sociological Review
Publication Date	1989
Link	https://research.tilburguniversity.edu/en/publications/3ee9ca1a-0e9c-487d-827e-2fe7609456ec
Citation	de Graaf, N D, Hagedaars, J A P & Luijkx, R 1989, 'Intragenerational stability of postmaterialism in Germany, the Netherlands and the United States', European Sociological Review, vol. 5, no. 2, pp. 183-201.
Download Date	2026-03-12 22:09:38
Rights	<p>General rights</p> <p>Copyright and moral rights for the publications made accessible in the public portal are retained by the authors and/or other copyright owners and it is a condition of accessing publications that users recognise and abide by the legal requirements associated with these rights.</p> <ul style="list-style-type: none"> - Users may download and print one copy of any publication from the public portal for the purpose of private study or research. - You may not further distribute the material or use it for any profit-making activity or commercial gain - You may freely distribute the URL identifying the publication in the public portal" <p>Take down policy</p> <p>If you believe that this document breaches copyright please contact us providing details, and we will remove access to the work immediately and investigate your claim.</p>

**Intragenerational Stability of Postmaterialism in Germany, the Netherlands
and the United States**



Nan Dirk de Graaf; Jacques Hagedaars; Ruud Luijkx

European Sociological Review, Vol. 5, No. 2 (Sep., 1989), 183-201.

Stable URL:

<http://links.jstor.org/sici?sici=0266-7215%28198909%295%3A2%3C183%3AISOPIG%3E2.0.CO%3B2-R>

European Sociological Review is currently published by Oxford University Press.

Your use of the JSTOR archive indicates your acceptance of JSTOR's Terms and Conditions of Use, available at <http://www.jstor.org/about/terms.html>. JSTOR's Terms and Conditions of Use provides, in part, that unless you have obtained prior permission, you may not download an entire issue of a journal or multiple copies of articles, and you may use content in the JSTOR archive only for your personal, non-commercial use.

Please contact the publisher regarding any further use of this work. Publisher contact information may be obtained at <http://www.jstor.org/journals/oup.html>.

Each copy of any part of a JSTOR transmission must contain the same copyright notice that appears on the screen or printed page of such transmission.

JSTOR is an independent not-for-profit organization dedicated to creating and preserving a digital archive of scholarly journals. For more information regarding JSTOR, please contact support@jstor.org.

Intragenerational stability of postmaterialism in Germany, the Netherlands and the United States

NAN DIRK DE GRAAF, JACQUES HAGENAARS AND
RUUD LUIJKX

ABSTRACT Inglehart's thesis of the 'Silent Revolution' states that the priorities of Western publics have gradually shifted from materialist toward postmaterialist values. An important aspect of this thesis is the socialization hypothesis, predicting that one's (post)-materialist values are stable during adulthood. This paper tests this hypothesis using panel data for the United States, Germany and the Netherlands. For this purpose several multiple indicator two-wave models are developed including (i) a correction for the dependency between the indicators (because of the ranking of the items) and (ii) item specific factors. Application of these models to the data indicates a strong stability of postmaterialist values during adulthood, especially for the United States and the Netherlands. The implications of the findings are discussed.

INTRODUCTION

Inglehart's postmaterialist Value Change thesis can be considered to have initiated a research line influential in both sociology and political science in the 1970s and 1980s. The Value Change thesis holds that under the influence of material prosperity, the basic values of Western publics have been changing gradually, from an emphasis on materialist goals, such as economic and physical security, towards an increased emphasis on postmaterialist goals, such as quality of life, belonging and esteem needs (Inglehart, 1971, 1977, 1989).

Inglehart's thesis has inspired much research in Western Europe and the United States (cf. Böltken and Jagodzinski, 1985; Lafferty and Knutsen, 1985; Thome, 1985; Savage, 1985; Van Deth, 1984; De Graaf and De Graaf, 1988; De Graaf, 1988). The widespread interest in the Inglehart thesis is understandable, since its implications are pervasive: we can expect change in basic social and political norms, in people's motivations to work and in political cleavage structures, as well as the rise of new types of political movements and new political

issues. A large body of empirical evidence has been presented indicating that materialist to post-materialist value change is indeed taking place (Inglehart, 1971, 1977, 1981, 1984, 1985a, 1985b; Dalton, 1977; Barnes, Kaase *et al.*, 1979; Dalton, Flanagan and Beck, 1984).¹

Inglehart's Value Change thesis is mainly based on two central hypotheses. The first one is the scarcity hypothesis, which states that 'an individual's priorities reflect the socio-economic environment: one places the greatest subjective value on those things that are in relatively short supply' (Inglehart, 1981: 881). The second one, the socialization hypothesis, states that 'the relationship between socio-economic environment and value priorities is not one of immediate adjustment: a substantial time lag is involved, for, to a large extent, one's basic values reflect the conditions that prevailed during one's pre-adult years' (Inglehart, 1981: 881). Since generations born after World War II have been socialized in relative affluence and the satisfaction of their basic needs like food and shelter is no longer problematic, it is predicted that they will develop new, so-called postmaterialist

values concerning quality of life. The implication of the socialization hypothesis is that individuals have rather stable value priorities, in the sense that differences between generations remain the same over a long period. If stability is not present, one cannot predict an intergenerational value change and an important part of the theory would be refuted. It is to be noted that stability of differences between generations does not exclude period effects; that is, period effects that affect all cohorts in the same manner, since such period effects do not have an impact on differences between generations.²

One aim of this paper is to provide a new international test of intragenerational attitudinal stability over long time periods. For this purpose a Dutch three-wave panel and a German and American two wave panel will be analyzed. These data contain a number of ranked materialist and postmaterialist items. To test the stability of postmaterialism one needs to construct a (post)materialist index. In most research this index is not obtained by applying factor analysis. The reason is that factor analysis assumes that the scores on the indicators are independently observed, and this assumption does not hold for rank ordered items. Data obtained from a ranking procedure of items show ipsative properties (Cattell, 1944). Ipsative properties have to do with dependency between rank ordered items; when the order of all items but one is known, the rank order of all items is fixed, because the sum of the ranks is a constant. Thus, the ipsativity that besets rank ordered items makes the application of common factor analysis objectionable. An aim of this paper is to correct for this ipsativity, which in turn allows the application of linear structural models.

The outline of the paper is as follows. First, brief attention will be paid to previous research on the intragenerational stability of postmaterialist values. Second, we will give an overview of how indices are constructed using postmaterialist items. Third, it is argued that a previous attempt by Inglehart (1985b) to estimate a model with one latent postmaterialist variable is incorrect. Fourth, a description is given of how to estimate a one latent variable model using two sets of ipsative measurements. Fifth, a large number of multiple indicator two-

wave models are presented, estimating the stability of postmaterialism over several periods of time. Finally we will evaluate the theoretical and methodological implications of the results obtained.

RESEARCH ON THE INTRA- GENERATIONAL STABILITY OF POSTMATERIAL VALUES

Dalton (1981) investigated the stability of postmaterialism using data from Germany. Applying a structural equation model, he found a standardized stability coefficient of 0.70. Dalton's conclusion is that postmaterialist values are quite stable, even after controlling for life cycle effects. It should be noted that Dalton did not analyse Inglehart's original items. Also, he used rated items instead of the original ranked items. Jagodzinski (1984) criticized Dalton's conclusion heavily and stated that his conclusion is mainly based on a misuse of LISREL. Jagodzinski argued that a combination of low factor loadings and misspecification may result in high stability coefficients. In this paper we will conclude that LISREL, when improperly applied, can indeed produce the type of result that Jagodzinski warns against. Yet, it will be shown that one can readily detect this kind of misspecification.

Van Deth (1983) analyzed the ranked items of data in the Dutch Political Action panel study. He concluded that there is not much stability over a period of five years. This conclusion is based on a turnover table in which postmaterialism is classified in four categories (postmaterialist, mixed postmaterialist, mixed materialist, and materialist). The intragenerational correlation Van Deth found for this four-by-four table was 0.48. The size of this correlation will be influenced by the true stability of the underlying attitude *and* by the reliability of the measurements. In this respect, it is of interest that in another study, Van Deth (1983) applied a ranking and a rating procedure in one interview. The correlation between the ranking and the rating measurements appeared to be 0.46. If the correlation over a period of five years is almost the same as a correlation over a few minutes, there is a strong indication that the intragener-

ational stability is very high (cf. Carmines and Zeller, 1979). Also, if the stability is high, one may conclude, in this case, that the reliability is very low.³ This makes it even more relevant to correct for measurement error when investigating the stability of postmaterialist attitudes.

Van Deth did not employ a factor analysis because of the ipsativity that besets the measurement procedure. The disadvantage is that he could not then correct for measurement unreliability. In this paper we present an improved method for dealing with the ipsativity problem, applying the latent variable approach, and it is shown that with the 'Inglehart items' it is possible to correct for measurement error. Building on the work of Jackson and Alwin (1980), we propose a technique that enables one to measure the underlying attitude dimension in a more reliable way.

Inglehart (1985b) himself carried out a LISREL analysis, taking ipsativity into account. His analysis contains technical flaws as will be pointed out later. He found a stability coefficient of 0.76 over a period of seven years. Ironically, however, this technical flaw does not work in favor of his thesis: if anything, his analysis underestimates the underlying attitudinal stability.

THE MATERIALIST AND POSTMATERIALIST ITEMS

In most publications mentioned above the postmaterialist value indices are constructed using rather arbitrarily rules of classification. The items on which these indices are based are the following two sets of questions (Political Action Codebook, 1979: 51–56):

A. The four item question:

In politics it is not always possible to obtain everything one might wish. On this card, several goals are listed.

If you had to choose among them, which one seems most desirable to you? Which will be your second choice? Which will be your third choice?

1. Maintain order in the nation
2. Give people more say in the decisions of the government
3. Fight rising prices
4. Protect freedom of speech

1 and 3 are materialist values; 2 and 4 are postmaterialist values.

B. The eight item question:

Here are some more goals and objectives people say our country as a whole should concentrate on. Of course, all of these are important to all of us in one way or another, but which three are the most important? Which is most important; which next; which third most important; which least important; which next-to-least; which third least important?

5. Maintain a high rate of economic growth
6. Make sure that this country has strong defense forces
7. Give people more say in how things are decided at work and in their community
8. Try to make our cities and countryside more beautiful
9. Maintain a stable economy
10. Fight against crime
11. Move toward a friendlier, less impersonal society
12. Move toward a society where ideas are more important than money

5, 6, 9 and 10 are materialist values; 7, 8, 11 and 12 are postmaterialist values.

There are different sorts of indices found in the literature. In these indices not all available information contained in the ranking of the items is used. The rankings are collapsed and, therefore, no distinction is made between first and second most important. If the factor analysis technique had been used no loss of information would have occurred. However, to apply factor analysis, one has to solve the problem caused by the ipsative nature of the ranked data.

THE LATENT VARIABLE APPROACH

Inglehart's attempt

In a recent article Inglehart (1985b) applied factor analysis using the rank ordered items mentioned above. Inglehart states that 'It was necessary to omit one item from the battery presented in each year, because otherwise the rankings of any 11 items would fully determine the rankings of the remaining item' (1985b: 111). This seems to imply that one set of 12 rank ordered items is used and not the two separate sets (i.e. the rank order of items 1 to 4 and rank order of items 5 to 12 separately) from the Political Action Survey. Yet this is not the case. Therefore, a second indicator should have been deleted as well. Actually, without deleting a second indicator it is logically impossible to get parameter estimates out of such a model.

The only information in the text about the correction for the ipsative nature of the data is that a modified form of the ipsative correction, proposed by Jackson and Alwin, is applied (Inglehart, 1985b: 111). How exactly this was done is not made clear, and it appears impossible to replicate the results using the Jackson and Alwin approach. The fit of the LISREL model and the degrees of freedom (χ^2 is given as 0.086 which, with $df = 197$, seems more likely to be the probability level instead of the χ^2 statistic itself) need some further clarification.

In the following section, we will show how to construct a latent variable using two or more sets of ipsative measurements.

Modeling latent postmaterialism

First, we shall apply a latent variable model using the four and eight item sets. As a first step, we have to assign scores to the responses on the items. The scores of the first four items are (question A):

1 = most desirable; 2 = second choice; 3 = third choice; 4 = last choice

and for items 5 to 12 (question B):

1 = most important; 2 = second important; 3 = third important; 4.5 = fourth and fifth important; 6 = third least important; 7 = second least important; 8 = least important.

It should be noticed that for items 5 to 12 only the first three and the last three rankings are known. Because of the fact that the first three and the last three rankings are known, we give the remaining two items (fourth and fifth important) the average score of 4.5.⁴ Next, we will give a description of how to correct for ipsativity in the most simple item set, that is, the four items of question A, following suggestions of Jackson and Alwin (1980, 1982).

Suppose respondents choose at random the most important item out of two. It is obvious that the correlation between the two items is -1.0 . Similarly, when three items are randomly ranked the correlation between any two of these variables is -0.5 . More generally, with a random ranking variables x_1, \dots, x_p of p items, the sum of the rankings is fixed, the covariance

matrix is singular and the expected correlation between any two variables is $-1/(p-1)$.

A standard assumption of factor analysis is non-singularity of the covariance matrix Σ_{xx} of the ranking variables x . In two articles on the factor analysis of ranking variables, Jackson and Alwin (1980, 1982) describe how to apply factor analysis in such a context. They start from the basic assumption that there exists a rating score for each item and that the ratings are 'translated' by the respondents into rankings. The general goal of Jackson and Alwin is to reconstruct the original factor model for the unobserved ratings on the basis of the observed rankings.⁵ To the extent that the basic assumption is true, their procedure is capable of reconstructing the original structure of the ratings. In this transformation process the information about the size of the factor loadings as such is lost; that is, the factor loadings pertaining to a particular factor sum to zero and they are expressed in terms of the deviation of the mean of original factor loadings. In a formal sense this translation can be described as follows,

$$x = (I - p^{-1}U)y = Ay \quad (1)$$

where y is the unobserved rating, p is the number of items, U is a $p \times p$ matrix of unities, and as A symmetric

$$\Sigma_{xx} = A\Sigma_{yy}A \quad (2)$$

With an increase of the number of items x tends to y . The ipsative transformation in equation 1 centers the scores around the individual's mean. The rows of Σ_{xx} sum to zero.

We assume a factor model of y with k factors,

$$y = \Lambda_y\eta + \epsilon \quad (3)$$

where Λ_y is the $k \times k$ matrix of factor loadings, η is the k -vector of individual factor scores. The error terms have the usual assumptions.

According to Jackson and Alwin the ipsative factor model may be written as

$$x = (\Lambda_x|A) \begin{pmatrix} \eta \\ \epsilon \end{pmatrix} \quad (4)$$

Factor analysis, however, still cannot be applied, because the covariance matrix Σ_{xx} is singular. A nonsingular 'submatrix' may be obtained by deleting a row and column for an arbitrarily selected variable. This results in

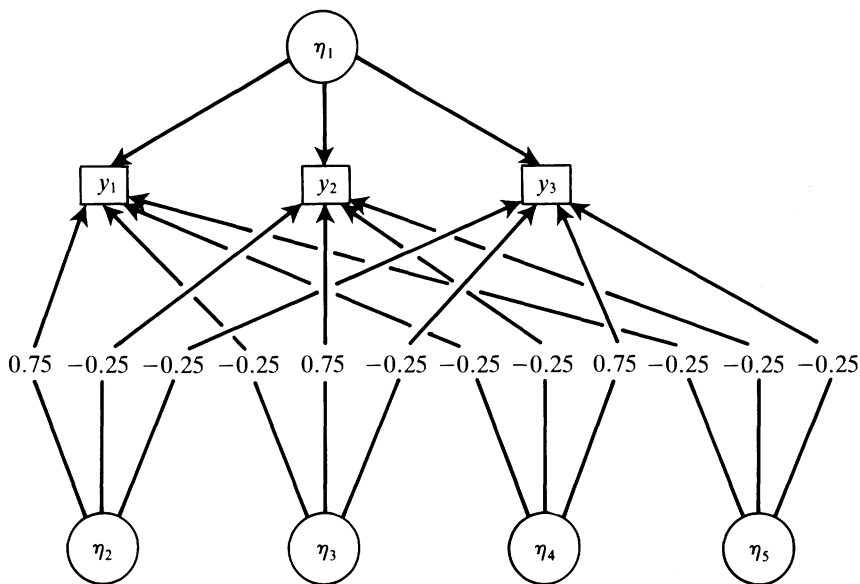

FIGURE 1 Measurement model for postmaterialism including four latent phantom variables correcting for the ipsative structure

Submatrices B_2 and B_6 correct the ipsative structure. In this factor loading matrix rows corresponding to variables 4 and 8 are omitted, because the matrix must be nonsingular. It should also be noticed, that again $\lambda_{4,1}$ may be obtained by taking the negative of the sum of $\lambda_{1,1}$, $\lambda_{2,1}$ and $\lambda_{3,1}$. Accordingly, $\lambda_{8,1}$ may be obtained by taking the negative of the sum of $\lambda_{5,1}$, $\lambda_{6,1}$, $\lambda_{7,1}$ and $\lambda_{9,1}$ through $\lambda_{12,1}$. For the measurement model we have still one latent variable, and for the ipsative correction 12 phantom latent variables.

It is now established how to modify the standard procedures in order to obtain a factor model with one latent variable for the (post)-materialist value orientation in analyzing two separate sets of rank ordered items. This gives the opportunity to apply the ipsativity correction in a covariance structure model. In the next section, a specific covariance structure model is presented; that is, a multiple indicator two-wave model including the correction for ipsativity. In such a model the intragenerational stability of postmaterialism can be estimated correctly. This stability coefficient will answer the question to what extent postmaterialism is intragenerationally stable.

INTRAGENERATIONAL STABILITY OF POSTMATERIALISM IN GERMANY, THE NETHERLANDS AND THE UNITED STATES

For the analysis, the Political Action data two-wave panel studies of the United States, Germany and the Netherlands will be used.⁷ The periods of data collection were:

West Germany N = 912 fieldwork		Netherlands N = 780 fieldwork		United States N = 933 fieldwork	
wave 1	wave 2	wave 1	wave 2	wave 1	wave 2
2/74	4/80	4/74	11/79	6/74	2/81
5/74	6/80	8/74	4/80	9/74	4/81

To test the socialization hypothesis properly, persons who had not finished their primary socialization period at the time of the first interview have to be excluded. In this respect, every choice of age is arbitrary. Nevertheless, it is assumed that the socialization process ends at the age of 20. Therefore, an age selection of persons older than 19 years in 1974 is applied. Also, we deleted listwise the missing values. The covariance matrices are presented in Appendix A.

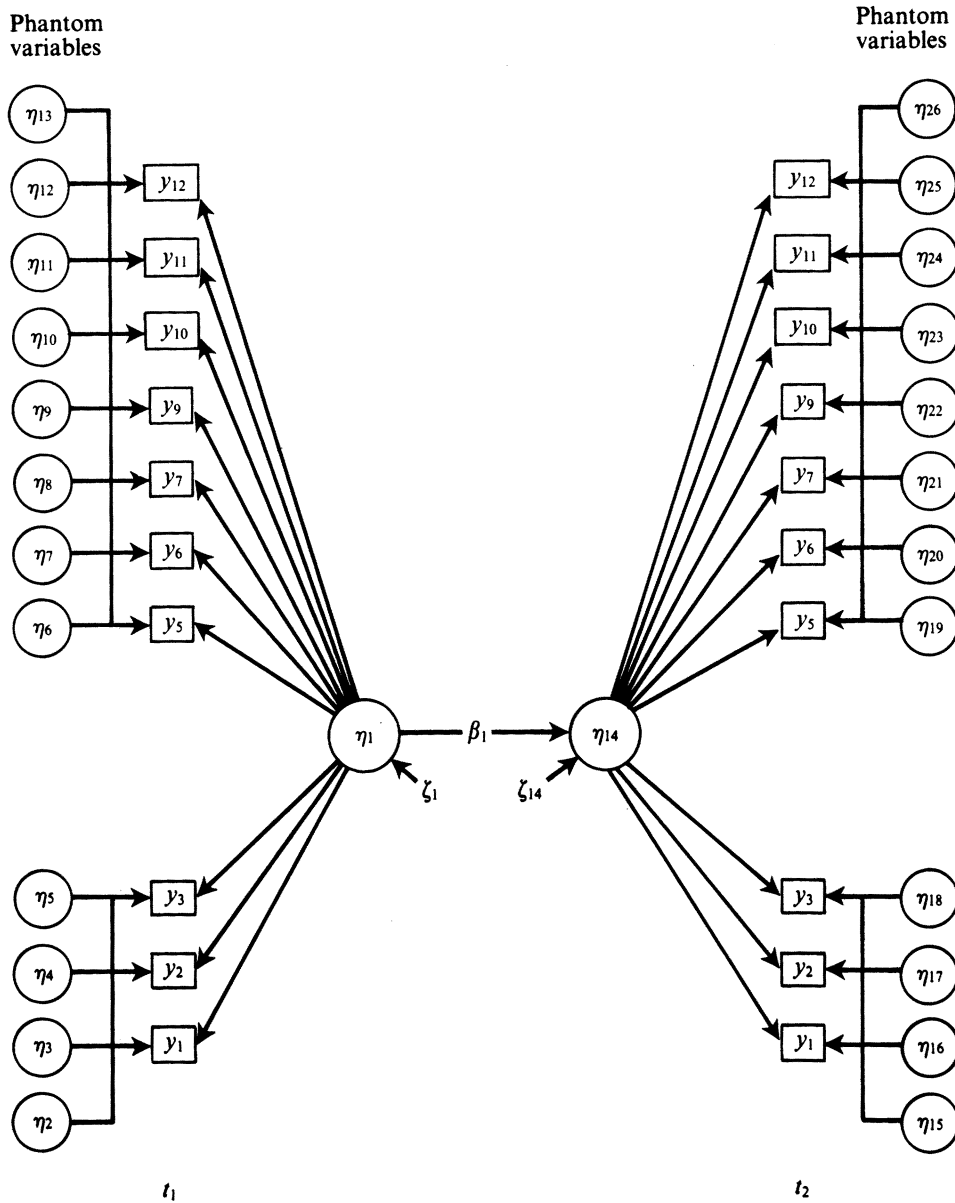

FIGURE 2 Multiple indicator two-wave model for postmaterialism

In order to estimate the intragenerational stability of the postmaterialist value orientation through time, a multiple indicator two-wave model will be applied. The two-wave model is visualized in Figure 2.

Since there are two time points (i.e. t_1 and t_2), two latent postmaterialist variables are postulated in Figure 2. Each item is determined by a

latent variable, ignoring the phantom variables. In case of perfect stability of the postmaterialist value orientation, the following should hold for the standardized coefficients:

$$\beta_1 = 1$$

On the left side is the measurement model for t_1 and on the right side the measurement model for

TABLE 1 *Results of the nested models comparison for West Germany, the Netherlands and the United States*

Model		df	West Germany N = 660		Netherlands N = 493		United States N = 710	
			χ^2	BIC	χ^2	BIC	χ^2	BIC
1.	Equal ψ and λ_y	186	507	-700	716	-438	923	-298
2.	Equal λ_y	174	477	-653	705	-347	895	-157
3.	No equality constraints	165	462	-609	699	-324	888	-195

Model with ufl ^(a) for similar items		df	West Germany N = 660		Netherlands N = 493		United States N = 710	
			χ^2	BIC	χ^2	BIC	χ^2	BIC
4.	Equal ufl and ψ and λ_y	176	458	-685	477	-614	631	-525
5.	Equal ufl and ψ	167	440	-644	468	-567	615	-482
6.	Equal λ_y and ψ	166	431	-631	469	-560	592	-498
7.	Equal ufl and λ_y	164	425	-640	466	-551	601	-476
8.	Equal ufl	155	410	-596	457	-504	587	-430
9.	No equality constraints	145	399	-543	444	-455	529	-422

Note: (a) ufl = unique factor loadings of the item specific factors.

t_2 . For each year there are 12 phantom η variables to correct for the ipsativity of the observed variables as shown in the previous paragraph. The phantom η 's correcting for ipsativity for t_1 are on the left and the phantom η 's correcting for ipsativity for t_2 are on the right in Figure 2. There is one latent variable for every year indicating the postmaterialist value orientation for that specific year. Factor loadings are estimated for the latent postmaterialist variables only. For each year there are 10 indicators, i.e. y_1 - y_3 , y_5 - y_7 , y_9 - y_{12} ; y_4 and y_8 are omitted. Between η_1 and η_2 the stability coefficients β_1 is estimated.

The results of the analysis are to be seen in Table 1. Nineteen Λ_{ys} are estimated. To identify the model, the first factor loading of the latent variables for t_2 is fixed at 1. Our first model is a base-line model in which the measurement model for every year is exactly the same. All corresponding λ 's are equal, as are the variances of the corresponding latent phantom variables; that is, equal ψ for all latent fake variables (see model 1 in Table 1). We think it is preferable to start with the model with the largest amount of stability constraints. The result, however, is not satisfactory since the χ^2 value is rather high in comparison to the degrees of freedom. In order

to improve the fit, other models with less equality constraints will be used. For comparison of the models we will use the bic-coefficient: $bic = \chi^2 - (df \log N)$ (Raftery, 1986). The more negative the bic coefficient the better the fit of the model. As can be seen in Table 1, the most restricted model resulted in the lowest bic-coefficient. Nevertheless, this model does not fit satisfactorily. Therefore, other models allowing for unique factors will be fitted.

The second series of models have item specific factors (models 4 through 9). Every item occurs twice in each model. The specific meaning of each item may cause extra correlation between the two measurements of that particular item, which cannot be explained by the common factors. It is possible to take this extra source of correlation into account by introducing an item specific factor for each of the 10 items (see, for example, Jagodzinski, Kühnel and Schmidt, 1987). LISREL gives the opportunity to model the common and the unique factor of every item.

In Figure 3 a model is presented in which item specific factors are incorporated. Each item specific or unique factor determines two indicators, measured similarly but at a different

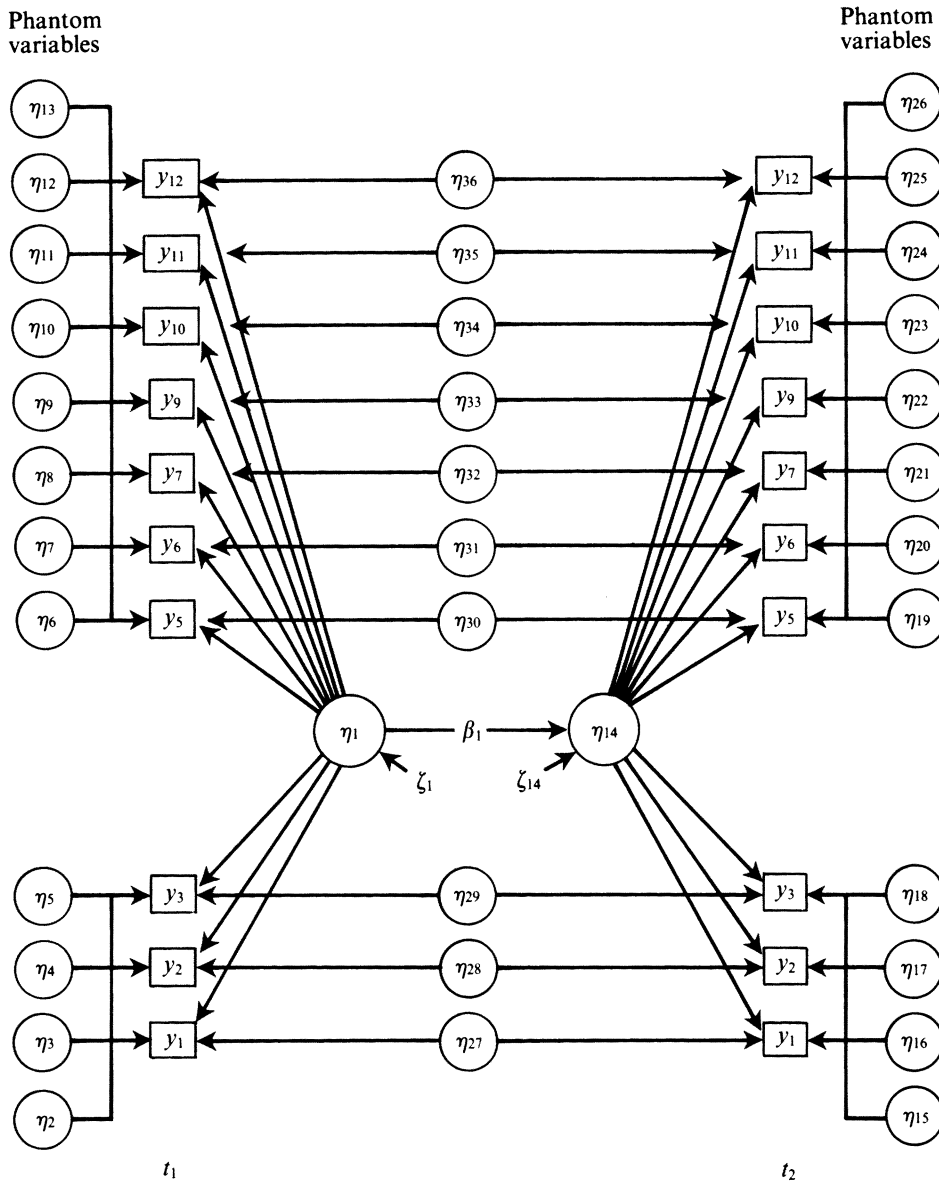

FIGURE 3 Multiple indicator two-wave model for postmaterialism with item specific factors

time. On each λ_y we specify an equality constraint in such a way that the two factor loadings of an item specific factor are equal. Compared to model 1, this results in a loss of 10 df and a large gain of χ^2 for the USA and the Netherlands. For these two countries model 4 has the lowest bic-coefficients. Other nested models, also with unique factors, but with less constraints, are

shown in lines 5 through 9 of Table 1. Neither of these models produced better fits. The conclusion is that, for the models with the unique factors, the most restricted model gives the best fit.

Parameter coefficients which are equal over time indicate that the reliability of the measurement instrument is stable. Germany is more or

TABLE 2 *Unstandardized factor loadings of model 1 for West Germany and unstandardized factor loadings and unique factor loadings (ufl) of model 4 for the Netherlands and the United States. Standard errors are in parentheses.*

	West Germany		λ_y	Netherlands		ufl	se	λ_y	United States		se
	λ_y	se		se	ufl				se	ufl	
1.	0.40	(0.04)	0.63	(0.05)	0.15	(0.11)	0.36	(0.04)	0.28	(0.05)	
2.	-0.34	(0.04)	-0.49	(0.04)	0.30	(0.05)	-0.35	(0.04)	0.38	(0.04)	
3.	0.30	(0.04)	0.21	(0.05)	0.56	(0.04)	0.25	(0.04)	0.54	(0.03)	
4.											
5.	0.44	(0.07)	0.59	(0.08)	0.64	(0.08)	0.63	(0.07)	0.47	(0.09)	
6.	0.52	(0.07)	0.66	(0.07)	0.77	(0.06)	0.95	(0.08)	0.62	(0.07)	
7.	-0.36	(0.07)	-0.93	(0.08)	0.21	(0.25)	0.86	(0.08)	0.00	(>1)	
8.											
9.	0.27	(0.05)	0.18	(0.07)	0.48	(0.10)	0.41	(0.07)	0.61	(0.06)	
10.	0.76	(0.07)	1.33	(0.08)	0.28	(0.16)	0.57	(0.06)	0.32	(0.09)	
11.	-0.84	(0.08)	-0.77	(0.08)	0.29	(0.18)	-0.85	(0.07)	0.00	(>1)	
12.	-0.74	(0.08)	-0.93	(0.09)	0.00	(>1)	0.94	(0.08)	-0.00	(>1)	

	West Germany		Netherlands		United States	
B	0.78	(0.09)	0.86	(0.05)	0.70	(0.06)
β	0.68		0.95		0.81	

less an exception in comparison to the other two countries. The model with the best fit, according to the bic-coefficient, is the most restricted model, that is, the model with no unique factors (model 1). Since we cannot improve the fit of model 1 for Germany and model 4 for the United States and the Netherlands, we will discuss the stability parameter estimates of these models. These parameters are presented in Table 2.⁸

It is revealed that the standardized stability coefficients are very high for the United States and the Netherlands, 0.81 and 0.95 respectively (model 4).⁹ A somewhat lower coefficient for the United States is to be expected, since the time interval between the measurement moments for the United States are extended for about a year compared to the Netherlands. The results for both countries indicate that postmaterialist values are stable over a rather long time period.

Since the stability coefficients are fairly high, we will finally test the model in which perfect stability occurs, i.e. $\beta_1 = 1$. As we are analyzing a covariance matrix, we will fix ζ_{14} at 0, so that

β_1 is forced to be 1. This results for the Netherlands are: with 177 df, $\chi^2 = 479$; bic = -618. This bic-coefficient is even lower than for model 4. Consequently, the model with perfect stability represents the Dutch data most adequately. The model with the restriction of perfect stability does not hold for the United States, since bic = -515 ($\chi^2 = 647$), which is higher than the bic-coefficient of model 4.

Table 2 shows that the stability coefficient for West Germany is the lowest, i.e. 0.68 (model 1). Also the same model, but with the restriction of perfect stability (187 df; $\chi^2 = 496$; bic = -676) did not improve the fit. Although the time in between the interviews for Germany exceeds six months, it is unlikely that this accounts fully for the lower stability in comparison to the Netherlands. A standardized coefficient of 0.68 is not an extremely low coefficient, but the German people appeared to have a less stable postmaterialist value orientation than the American and Dutch people. Why is this? Of course, *post hoc* explanations are to be distrusted in general. Yet, it might be argued that Germany is a special case, since, of these three

countries, Germany suffered most in World War II. This might have led to an extreme value change in generations who experienced the war. An additional cause might be that, after the war, the Allies started a re-education program for the German people. Their old social and political values were more or less extinguished, and they did have to learn new values. Therefore, this enforced value change might have led to a value instability, still noticeable in the 1970s.

This explanation can be tested by comparing different age groups. Unfortunately, a full test with these data is not possible, since for the post-war generation we cannot obtain more cases than covariances. For the older generations it is, however, possible to estimate a model similar to model 1. Selection of respondents older than 5 years of age when World War II ended results in 513 cases. The standardized stability coefficient for this group is 0.56 and the unstandardized coefficient 0.62. Both coefficients confirm to some extent our expectations.¹⁰

INTRAGENERATIONAL STABILITY IN THE NETHERLANDS

In this section we will estimate intra-individual stability over a period of eleven years. For the analysis, data of a Dutch three-wave panel 1974–1979–1985 will be used.¹¹ The analysis, however, will be restricted to 1974 and 1985 only. The reason is that the covariance matrix of the complete three-wave panel, owing to the limited number of observations, has more covariances than cases, which generally leads to unstable parameter estimates. The covariance matrix for the (post)materialist items of these two waves (1974–1985) is presented in Appendix B.

Since there are again two time points, the same procedure will be applied as in the previous section. In Table 3 the results of identical nested models to those of Table 1 are compared. The most constrained model without item specific factors fitted rather poorly. Models with item specific factors show a large gain in χ^2 . The bic-coefficients reveal that the most constrained model results in the best fit, that is, the model with item specific factors and equal β , ψ and λ_y parameters.

TABLE 3 Results of the nested models comparison for the Netherlands 1974–1985

Model	df	χ^2	bic
1. Equal ψ and λ_y	186	613	-492
2. Equal λ_y	174	559	-474
3. No equality constraints	165	557	-423
Model with ufl for similar items	df	χ^2	bic
4. Equal ufl and ψ and λ_y	176	483	-562
5. Equal ufl and ψ	167	479	-513
6. Equal λ_y and ψ	166	446	-540
7. Equal ufl and λ_y	164	438	-536
8. Equal ufl	155	435	-485
9. No equality constraints	145	416	-445

TABLE 4 Unstandardized estimates of model 4 for the Dutch 1974–1985 panel. Standard errors are in parentheses.

	λ_y	se	ufl	se
1.	0.74	(0.05)	1.	0.00 (>1)
2.	-0.55	(0.05)	2.	0.23 (0.07)
3.	0.14	(0.05)	3.	0.49 (0.04)
4.				
5.	0.66	(0.09)	5.	0.61 (0.10)
6.	0.74	(0.08)	6.	0.81 (0.07)
7.	-1.03	(0.09)	7.	0.00 (>1)
8.				
9.	0.20	(0.08)	9.	0.00 (>1)
10.	1.18	(0.08)	10.	0.31 (0.04)
11.	-0.66	(0.09)	11.	0.51 (0.12)
12.	-0.91	(0.10)	12.	0.00 (>1)

B = 0.81 (0.06); β = 0.87

The parameter estimates of this model are presented in Table 4. The stability coefficient is relatively high (standardized coefficient 0.87; unstandardized 0.81 (0.06)).

Our analysis of the Dutch data supports strongly the key assumption of Inglehart's thesis that individuals have rather stable value priorities. The stability, however, is not perfect, since an additional restriction of $\beta_1 = 1$ did not improve the fit (bic = -545) of model 4. Despite this result, we conclude that the postmaterialist value orientation is very stable over a period of 11 years. Of course, one has to recognize that in

this kind of analysis the average of a latent variable is zero. The implication is that one cannot detect a structural increase of postmaterialism or materialism.¹² However, as previously noticed, one should allow for such an increase, as the hypothesis states that the differences between the generations remain the same.

DISCUSSION

The empirical results suggest high estimates of stability, especially for the Netherlands and the United States. However, one could think of some criticism of the procedure applied and of the suggested unidimensionality of postmaterialism. The first criticism concerns the influence of correlated error on stability coefficients. It is sometimes argued that in some multiple indicator, multiple-wave models the stability coefficients are artificially high, as there might be memory effects which could produce correlated errors. This criticism does not apply to our analysis, as a proper correction was applied for this phenomenon by including the item specific factors.

In the literature some authors warn against the application of models with low factor loadings, because low loadings as such may result in high stability coefficients. Jagodzinski for instance analyzed an artificial correlation matrix consisting of 0.040 and 0.036 correlations and also a correlation matrix generated at random, both of which resulted in large stability coefficients (Jagodzinski, 1984: 227–229). However, Jagodzinski states that taking the standard errors into account will lead to the conclusion that the β coefficient and all factor loadings of his LISREL model, estimated from the second correlation matrix, are not significant. However, in our case the estimated stability coefficients are clearly significant. Moreover, when fixing the β coefficient of Jagodzinski's LISREL model at zero, pertaining to the first correlation matrix, we obtained a well fitting model for his hypothetical data as well. In contrast, when the β coefficient is fixed at zero for the Dutch two-wave model (1974–1985), the χ^2 the statistic deteriorates with 176 χ^2 points (1 df) and bic increases with 91 points. Given these arguments,

it is plausible that the stability of the underlying postmaterialist value orientation is not an artefact.

The other criticism concerns the assumption of one-dimensionality. In Inglehart's conception, one dimension is assumed. Some authors have been of the opinion that the underlying structure of the postmaterialist and materialist items is not one-dimensional, but two-dimensional (see Jagodzinski, 1984; Van Deth, 1983). It is, however, rather difficult to estimate a two-dimensional model using ipsative measures. This is more a technical problem, concerning the applied statistical program, than a substantive problem, and one to be solved in the near future.

A crucial assumption underlying the analysis is that rating and ranking procedures of the items concerned measure the same attitude, and that the rankings result from a rather simple transformation of the ratings. However, the discussion on the issue of whether ranking and rating measure the same attitude is not conclusive (cf. Rokeach, 1973; Van Deth, 1983; Alwin and Krosnick, 1985).

Finally, some authors warn against the possible misinterpretation of stability coefficients in latent variable models. Converse (1980) is the most critical on this point. In a comment on Judd and Milburn (1980), who attempted to disconfirm the Converse thesis that the public at large does not have meaningful and stable attitudes, Converse argues: 'Take the contrasting samples and correct the data from each attenuation due to measurement unreliability, either by time-honored means or by the kind of 'chucking off' into the measurement model that newer methods like LISREL invite. This almost certainly means that you clean out more measurement noise from the less informed sample than from the more informed one, but there is no need to make any point of that. What is important is that the adjusted data with the reliability differentials corrected away can be used to disconfirm the Converse expectation that such differentials between samples will be found'.

As in classical reliability theory, latent variables in LISREL models are supposed to represent true scores. Error has two components: measurement error and random behavior. The

distinction between these two components of error is probably not always clear (cf. Inglehart, 1985b).¹³ Stability in LISREL means stability between variables corrected for both components of error. Yet, this sort of stability is still of theoretical interest, since it is important to know whether persons, in case they do not answer randomly, have stable values or attitudes over time.

CONCLUSIONS

Inglehart's thesis of the 'Silent Revolution' states that the priorities of Western publics have gradually shifted from materialist towards postmaterialist values. A crucial component of this thesis is the socialization hypothesis. One implication of this hypothesis is that value priorities should be stable within each generation. The question of this paper was to what extent postmaterialist values are intragenerationally stable over time. Research on this topic, analyzing the original items, employs a value index which consists of a somewhat arbitrary classification of the 12 (post)materialist items. These items are obtained by a particular ranking procedure, which implies ipsativity and leads to dependent observations. Because of this, relations between the items cannot be analyzed by standard factor analysis techniques. In this article it has been shown how to modify the standard procedure in order to estimate the parameters of the factor analysis model with one latent variable using the two separate sets of rank ordered (post)materialist items.

For this purpose, a multiple-indicator multiple-wave model has been developed, taking the ipsative properties of the data into account. The hypothesis of stability of postmaterialist values was tested by estimating coefficients for postmaterialism over a period of eleven years (1974-1979-1985) using a Dutch three-wave panel study and German (1974-1980) and American (1974-1981) two-wave panel studies. The first baseline model fitted the data rather poorly, in terms of χ^2 test statistics. It was possible to improve the fit for the Dutch and American data by introducing a model including item specific factors. The stability coefficients estimated strongly corroborate Inglehart's basic

assumption that an individual's postmaterialist value orientation is stable after primary socialization.

In a recent article Inglehart (1985b) has also applied corrections for ipsativity in analyzing the Dearborn two-wave panel. We argued that Inglehart's attempt only partially succeeded. The stability coefficient estimated by Inglehart over a period of seven years was 0.76 and this coefficient was not estimated correctly. The stability coefficient obtained for the United States over a period of six years, using the proper correction for ipsativity, was even higher at 0.81.

The general answer to the question whether postmaterialist values are intragenerationally stable, is that postmaterialist values are indeed intragenerationally stable over long time intervals up to eleven years. There are, however, some international differences. The Dutch data show almost perfect stability and the data of the United States show a very high stability. West Germans, however, appeared to be less stable in their postmaterialist value orientation.

NOTES

1. It should be noted that not all researchers have found indications that the intergenerational value change is really taking place (cf. Van Deth, 1984; Bøltken and Jagodzinski, 1985).
2. Stability of differences does not exclude a linear life cycle effect either, that is, an effect indicating that after growing one year older, each generation changes its values exactly in the same manner. Apart from the fact that such perfect linear life cycle effects are not plausible, research has also shown that theoretically based life cycle indicators do not have a substantial impact on the postmaterialist value orientation (De Graaf, 1989: ch. 3).
3. The table from which this correlation of 0.46 is obtained is the following (Van Deth, 1983: 423).

Based on rankings	Based on ratings			Total
	Materialist	Mixed	Postmaterialist	
Materialist	197	165	13	375
Mixed	185	574	171	930
Postmaterialist	1	25	81	107
Total	383	764	265	1412

To what extent the correlation of 0.46 may be compared with the correlation of 0.48 is somewhat problematic, since in the above table three categories are used, and for the correlation of 0.48 a table with four categories has been used (it may be expected that the correlation of 0.48 would be somewhat lower if computed with a 3×3 table). Additionally one has to assume that the ranking and the rating procedures lead to equally reliable data.

4. It might be argued against these scores that rankings of these items have only meaning for each individual separately (Van Deth, 1983). The consequence is that when two individuals rank the same item on the same place, the score of this item does not have to be the same. In our procedure, however, such an item does have the same score for both individuals. We suppose that this assumption does not violate the estimating procedure.
5. For a more detailed description we refer to Jackson and Alwin (1980) and Alwin and Jackson (1982).
6. For convenience, another notation is used, i.e. Λ_y instead of Λ_x .
7. These data are to be obtained from the Zentral archiv für empirische Sozialforschung, University of Cologne: ZA-No. 1189. For further information about these data, see Jennings, Van Deth *et al.* (1989).
8. The reader may have the opinion that it is still possible to improve the fit of the models presented by deleting nonsignificant unique factor loadings. However, this strategy is not preferred, since no hypotheses are available concerning where unique factor loadings should not have a significant impact. Also, stability coefficients are the main point of interest. Leaving out nonsignificant unique factor loadings will not significantly change these coefficients.
9. It appeared that the stability coefficients of models 1 through 3 and 5 through 9 did not differ much from the stability coefficients estimated in model 4.
10. We have to be careful with such a conclusion. For example, another hypothesis which contradicts the explanation suggested in the text concerns severity of war experience. Cross-national research shows that severity of war experience has a negative impact on an individual's postmaterialist value orientation and traumatic experiences are suspected to cause 'stable' values (cf. De Graaf, 1988: 72–74). Since West Germany suffered, without any doubt, most of our three countries, it can be argued that this will also influence value stability positively. Yet these explanations are mere speculations and some caution is called for since we have only three cases at our disposal.
11. We refer to Van Deth (1986) for more information about the Dutch panel data. The first two waves are part of the Political Action project. Felix Heunks and Jan van Deth are responsible for the third wave. The first wave was gathered in Spring 1974, the second wave during Winter 1979/1980 and the third wave in Spring 1985. A total of 1,201 respondents were interviewed in the first wave. Seven hundred and eighty remained in the second wave and ultimately 526 remained in the third wave. We applied listwise deletion of missing values for the Inglehart items. These missing values and

an age selection of persons over the age of 19 resulted in an additional reduction of 28 per cent of the cases. The covariance matrix in Appendix B is based on the remaining 72 per cent, i.e. 379 respondents. This reduction in cases raises the question of whether only individuals remain who have a relatively stable value orientation. It is not known if this is the case, nor is it known to what extent our conclusions might be vitiated. The data of the first two waves are also used in the previous section.

12. It is possible with LISREL to relax the assumption of zero means, enabling one to estimate the average values of the latent variables separately (Jöreskog and Sörbom, 1986: v.14).
13. For example Inglehart (1985b) suggests that his structural equation analysis has the advantage above Converse's 'Black and White Model' that it corrects for measurement error. The crucial argument in his article is that his stability coefficient shows that there is not much random behavior. This is, of course, not true. The latent variable approach also corrects for random behavior, which undermines his main theoretical argument comparing his model with the Black and White Model.

ACKNOWLEDGEMENTS

We would like to express our gratitude to Jan van Deth for supplying the Dutch data of 1985. Also, we would like to thank Harry Ganzeboom, Ronald Inglehart, Wolfgang Jagodzinski, Peter Schmidt and Wout Ultee for their helpful comments.

REFERENCES

- Alwin D F, Krosnick J A. (1985): 'The Measurement of Values in Surveys: A Comparison of Ratings and Rankings', *Public Opinion Quarterly*, 49: 311–29.
- Alwin D F, Jackson D J. (1982): 'Adult Values for Children: An Application of Factor Analysis to Ranked Preference Data', in R M Hauser *et al.*, (eds), *Social Structure and Behavior*, New York: Academic Press: 311–29.
- Barnes S H, Kaase M *et al.* (1979): *Political Action: Mass Participation in Five Western Democracies*, Beverly Hills, CA: Sage.
- Böltken F, Jagodzinski W. (1985): 'In an Environment of Insecurity', *Comparative Political Studies*, 17: 453–84.
- Cattell R B. (1944): 'Psychological Measurement: Normative, Ipsative, Interactive', *Psychological Review*, 51: 292–303.
- Converse P E. (1980): 'Rejoinder to Judd and Milburn', *American Sociological Review*, 45: 644–46.
- Dalton R. (1977): 'Was There a Revolution?: a note on generational versus life cycle explanations of value differences', *Comparative Political Studies*, 9: 459–73.
- (1981): 'The Persistence of Values and Life Cycle Changes', *Politische Vierteljahresschrift, Sonderheft*, 12: 189–207.

- Dalton R J, Flanagan S C, Beck P A. (eds) (1984): *Electoral Change in Advanced Industrial Democracies*, New Jersey: Princeton University Press.
- De Graaf N D. (1988): *Postmaterialism and the Stratification Process: An International Comparison*, Utrecht University: ISOR-Press (dissertation).
- (1989): 'Individual and Structural Conditions Affecting Post-materialist values', in, Ganzeboom H B G, Flap H D, (eds), *New Social Movements and Value Change*, Amsterdam: SISWO publications: 5–50.
- De Graaf N D, De Graaf P M. (1988): 'Family Background, Postmaterialism and Life Style', *The Netherlands' Journal of Sociology*, 24: 50–64.
- Inglehart R. (1971): 'The Silent Revolution in Europe: Intergenerational Change in Post-Industrial Societies', *American Political Science Review*, 65: 990–1017.
- (1977): *The Silent Revolution: Changing Values and Political Styles among Western Publics*, New Jersey: Princeton University Press.
- (1979): 'Value Priorities and Socio-economic Change', in Barnes H, Kaase M *et al.*, *Political Action: Mass Participation in five Western Democracies*, Beverly Hills, CA: Sage.
- (1981): 'Post-materialism in an environment of insecurity', *American Political Science Review*, 75: 880–900.
- (1984): 'The Changing Structure of Political Cleavages in Western Society', in, Dalton R J, Flanagan S C and Beck P A, (eds), *Electoral change in advanced industrial democracies*, New Jersey: Princeton University Press, 25–69.
- (1985a): 'New Perspectives on Value Change, Responses to Lafferty and Knutsen, Savage and Böltken and Jagodzinski', *Comparative Political Studies*, 17: 485–532.
- (1985b): 'Aggregate Stability and Individual-Level Flux in Mass Belief Systems: The Level of Analysis Paradox', *American Political Science Review*, 79: 97–116.
- (1989): *Cultural Shift in Advanced Industrial Society*, (forthcoming).
- Jackson D J, Alwin D F. (1980): 'The Factor Analysis of Ipsative Measures', *Sociological Methods and Research*, 9: 218–38.
- Jagodzinski W. (1984): 'Wie transformiert man Labile In Stabile Relationen? Zur Persistenz postmaterialistischer Wertorientierungen', *Zeitschrift für Soziologie*, 13: 225–42.
- Jagodzinski W, Kühnel S, Schmidt P. (1987): 'Is There a "Socratic Effect" in Nonexperimental Panel Studies? Consistency of an Attitude Toward Questworkers', *Sociological Methods and Research*, 15: 259–302.
- Jennings K, Van Deth J. (eds) (1989): *Continuities in Political Action*, (forthcoming).
- Jöreskog K, Sörbom D. (1986): *LISREL: Analysis of Linear Structural Relationships by the Method of Maximum Likelihood (Version VI)*, University of Uppsala, Sweden.
- Judd C, Millburn M A. (1980): 'The Structure of Attitude Systems in the General Public: Comparison of a Structural Equation Model', *American Sociological Review*, 45: 627–43.
- Lafferty W M, Knutsen O. (1985): 'Postmaterialism in a Social Democratic State', *Comparative Political Studies*, 17: 411–30.
- Rafferty A E. (1986): 'Choosing Models for Cross-Classifications: Comment on Grusky and Hauser', *American Sociological Review*, 51: 145–46.
- Rokeach M. (1973): *The Nature of Human Values*, New York: Free Press.
- Savage J. (1985): 'Postmaterialism of the Left and Right', *Comparative Political Studies* 17: 431–51.
- Thome H von. (1985): 'Wandel zu postmaterialistischen Werten?: Theoretische und empirische Einwände gegen Ingleharts Theory' Versuch', *Soziale Welt*, 36.
- Van Deth J. (1983): 'Ranking the ratings: the case of materialist and post-materialist orientations', *Political Methodology*, 9: 407–31.
- (1984): *Politieke waarden*, Amsterdam: CT-Press (dissertation).
- (1986): 'Verandering van politieke orientaties in retrospectief', in, Bronner A E *et al.*, (eds), *Recente ontwikkelingen in het marktonderzoek*, Haarlem: 65–73.

AUTHORS' ADDRESSES

Nan Dirk De Graaf, Max Planck Institute for Human Development and Education, Lentzeallee 94, D-1000 Berlin 33, Federal Republic of Germany.

Jaques Hagenaars and Ruud Luijckx, Tilburg University, Department of Sociology, PO Box 90153, 5000 LE Tilburg, the Netherlands.

Manuscript received: March 1989.

APPENDIX A

Covariance matrix of the value items for the Netherlands (N = 493). The first 12 variables represent the first wave and the second 12 variables represent the second wave.

	1974												1979											
	1	2	3	4	5	6	7	8	9	10	11	12	1	2	3	4	5	6	7	8	9	10	11	12
1.	1.332																							
2.	-0.677	1.143																						
3.	-0.308	-0.272	1.238																					
4.	-0.347	-0.194	-0.659	1.201																				
5.	0.183	-0.163	0.128	-0.148	3.896																			
6.	0.456	-0.350	0.015	-0.120	0.070	2.640																		
7.	-0.809	0.655	0.022	0.133	-0.722	-0.977	4.470																	
8.	-0.164	0.022	0.163	-0.021	-0.853	-0.851	-0.320	3.758																
9.	0.296	-0.159	-0.283	0.146	-0.122	0.095	-0.819	-0.480	3.783															
10.	0.949	-0.679	0.361	-0.632	0.132	0.860	-1.476	-0.141	-0.309	4.052														
11.	-0.363	0.205	-0.162	0.320	-1.169	-0.846	-0.242	-0.488	-0.892	-1.541	4.399													
12.	-0.547	0.470	-0.244	0.321	-1.233	-0.991	0.085	-1.257	-1.577	0.778	4.822													
1.	0.462	-0.271	0.059	-0.250	0.252	0.268	-0.511	0.021	0.006	0.688	-0.346	-0.379	1.126											
2.	-0.324	0.337	-0.067	0.054	-0.141	-0.166	0.468	0.064	-0.103	-0.488	0.171	0.193	-0.574	1.105										
3.	-0.023	-0.123	0.431	-0.285	0.275	0.061	-0.035	-0.091	-0.210	0.311	-0.226	-0.086	-0.123	-0.409	1.138									
4.	-0.115	0.057	-0.422	0.480	-0.387	-0.163	0.077	0.005	0.307	-0.512	0.400	0.271	-0.429	-0.122	-0.606	1.157								
5.	0.255	-0.340	0.281	-0.196	1.421	0.103	-0.565	-0.026	0.286	0.548	-0.954	-0.813	0.246	-0.136	0.355	-0.464	4.156							
6.	0.349	-0.322	0.053	-0.080	0.212	1.233	-0.591	-0.434	0.231	0.677	-0.529	-0.799	0.288	-0.262	0.084	-0.111	0.118	2.776						
7.	-0.704	0.617	-0.126	0.214	-0.581	-0.720	1.524	0.010	-0.502	-0.812	0.309	0.771	-0.582	0.521	-0.050	0.112	-0.758	-0.946	4.577					
8.	-0.228	0.061	0.052	0.115	-0.388	-0.424	0.248	0.731	-0.146	-0.145	0.100	0.024	-0.227	0.157	-0.015	0.085	-1.073	-0.747	-0.247	3.124				
9.	0.203	-0.090	-0.374	0.260	0.316	0.248	-0.435	-0.577	1.112	-0.414	-0.125	-0.126	0.140	-0.165	-0.248	0.272	-0.086	0.122	-1.009	-0.530	3.612			
10.	0.657	-0.579	0.467	-0.546	0.622	0.589	-0.799	0.014	-0.308	1.898	-0.874	-1.141	0.707	-0.500	0.395	-0.602	0.392	0.426	-1.255	-0.451	-0.364	3.650		
11.	-0.211	0.257	-0.273	0.227	-0.870	-0.445	0.200	-0.016	-0.269	-0.940	1.398	0.943	-0.152	0.144	-0.353	0.361	-1.598	-0.847	-0.481	0.149	-0.495	-1.014	4.141	
12.	-0.322	0.395	-0.079	0.006	-0.732	-0.585	0.418	0.299	-0.405	-0.812	0.676	1.140	-0.420	0.241	-0.168	0.346	-1.151	-0.902	0.119	-0.227	-1.250	-1.385	0.146	4.650

Covariance matrix of the value items for West Germany (N = 660). The first 12 variables represent the first wave and the second 12 variables represent the second wave.

	1974												1980											
	1	2	3	4	5	6	7	8	9	10	11	12	1	2	3	4	5	6	7	8	9	10	11	12
1.	0.982																							
2.	-0.486	0.997																						
3.	-0.187	-0.303	0.902																					
4.	-0.310	-0.208	-0.413	0.931																				
5.	-0.188	0.032	0.262	-0.156	4.511																			
6.	0.272	-0.304	0.038	-0.006	-0.316	3.769																		
7.	-0.335	0.338	-0.057	0.054	-0.098	-0.983	3.918																	
8.	0.095	-0.123	0.083	-0.055	-0.687	-0.491	-0.691	2.969																
9.	0.069	-0.100	0.062	-0.030	0.137	-0.055	-0.213	-0.362	2.075															
10.	0.548	-0.454	0.175	-0.269	-0.460	0.222	-0.769	-0.002	-0.068	2.924														
11.	-0.162	0.269	-0.328	0.221	-1.468	-1.228	-0.825	-0.249	-0.737	-0.709	4.488													
12.	-0.299	0.293	-0.234	0.240	-1.612	-0.918	-0.338	-0.487	-0.777	-1.138	0.729	4.547												
1.	0.239	-0.137	0.084	-0.186	0.087	0.206	-0.086	0.144	0.005	0.248	-0.279	-0.326	1.123											
2.	-0.160	0.169	-0.137	0.129	0.039	-0.107	0.038	-0.134	-0.087	-0.075	0.147	0.178	-0.460	1.043										
3.	0.077	-0.119	0.196	-0.154	0.057	-0.059	-0.054	0.059	0.125	0.161	-0.205	-0.085	-0.170	-0.400	1.059									
4.	-0.156	0.088	-0.143	0.211	-0.183	-0.040	0.101	-0.070	-0.044	0.334	0.337	0.233	-0.493	-0.184	-0.490	1.167								
5.	0.078	-0.148	0.089	-0.019	0.421	0.259	-0.152	-0.186	0.215	-0.083	-0.411	0.063	0.159	-0.149	0.188	-0.198	4.484							
6.	0.174	-0.150	-0.032	0.008	0.227	0.462	-0.449	0.010	0.068	-0.042	-0.158	-0.117	0.286	-0.141	0.123	-0.267	0.051	4.200						
7.	-0.377	0.367	-0.068	0.078	0.136	-0.488	1.051	-0.126	-0.098	-0.199	-0.402	0.126	-0.378	0.372	0.109	0.114	-0.685	-1.171	4.639					
8.	-0.037	-0.081	0.063	0.054	-0.413	0.127	-0.093	0.316	-0.086	0.145	0.112	-0.110	-0.112	-0.055	0.030	0.137	-0.785	-0.622	-0.569	3.490				
9.	0.055	-0.052	0.012	-0.015	0.179	0.008	-0.116	-0.117	0.291	0.051	-0.172	-0.124	0.115	-0.178	0.087	-0.024	0.179	-0.249	-0.362	-0.527	2.668			
10.	0.370	-0.192	0.201	-0.379	0.407	0.021	-0.353	0.041	0.081	0.582	-0.295	-0.484	0.455	-0.349	0.399	-0.506	-0.402	0.141	-0.733	-0.555	-0.055	3.494		
11.	-0.133	0.097	-0.209	0.246	-0.535	-0.133	0.055	-0.054	-0.443	-0.181	0.852	0.439	-0.285	0.236	-0.443	0.491	-1.667	-1.300	-0.489	-0.189	-0.625	1.122	4.847	
12.	-0.130	0.159	-0.056	0.027	-0.422	-0.257	0.057	0.115	-0.028	-0.272	0.474	0.333	-0.241	0.263	-0.275	0.253	-1.174	-1.049	-0.629	-0.243	-1.028	-0.768	0.545	4.346

Covariance matrix of the value items for the United States (N = 710). The first 12 variables represent the first wave and the second 12 variables represent the second wave.

		1974												1981											
		1	2	3	4	5	6	7	8	9	10	11	12	1	2	3	4	5	6	7	8	9	10	11	12
1.	1-128																								
2.	-0.546	1-130																							
3.	-0.344	-0.315	1-326																						
4.	-0.239	-0.268	-0.667	1-174																					
5.	0.095	-0.119	0.270	-0.245	4-132																				
6.	0.407	-0.076	-0.081	-0.251	0.208	4-414																			
7.	-0.627	0.581	-0.129	0.174	-0.693	-1.061	4-328																		
8.	-0.122	-0.141	0.186	0.077	-0.873	-0.733	-0.704	3-340																	
9.	0.131	-0.130	0.202	-0.203	0.056	-0.199	-0.618	-0.492	3-522																
10.	0.338	-0.257	0.268	-0.350	-0.189	0.209	-1.012	0.335	-0.250	2-579															
11.	-0.121	0.104	-0.263	0.281	-1.311	-1.327	-0.008	-0.224	-0.975	-0.589	3-900														
12.	-0.101	0.037	-0.453	0.517	-1.330	-1.510	-0.231	-0.649	-1.043	-1.083	0.533	5-314													
1.	0.350	-0.191	-0.061	-0.097	-0.005	0.211	-0.230	-0.061	0.116	0.232	-0.160	-0.105	1-178												
2.	-0.185	0.353	-0.117	-0.052	-0.164	-0.149	0.280	-0.012	-0.126	-0.162	0.094	0.237	-0.555	1-265											
3.	-0.053	-0.075	0.444	-0.315	0.286	0.039	-0.190	-0.021	0.091	0.133	-0.079	-0.258	-0.337	-0.388	1-238										
4.	-0.112	-0.087	-0.266	0.464	-0.117	-0.102	0.140	0.093	-0.081	-0.203	0.144	0.127	-0.287	-0.323	-0.514	1-123									
5.	0.065	-0.078	0.111	-0.098	0.860	0.297	-0.345	-0.026	0.234	0.059	-0.391	-0.688	0.060	-0.288	0.232	-0.004	3-673								
6.	0.369	-0.115	-0.051	-0.204	0.497	1.555	-0.598	-0.253	0.170	0.326	-0.815	-0.862	0.269	-0.198	0.019	-0.090	0.293	3-807							
7.	-0.311	0.417	-0.164	0.058	-0.518	-0.573	0.873	-0.073	-0.172	0.228	0.293	0.398	-0.638	0.899	-0.223	-0.038	-0.725	-0.948	4-187						
8.	-0.062	-0.101	0.074	0.088	-0.214	-0.129	-0.004	0.614	-0.497	-0.116	0.244	0.102	0.065	-0.193	-0.036	0.164	-0.698	-0.517	-0.521	2-877					
9.	0.132	-0.076	0.016	-0.072	0.250	-0.119	-0.267	-0.241	0.931	-0.182	-0.346	-0.026	0.092	-0.218	0.238	-0.112	-0.001	-0.153	-0.746	-0.384	3-033				
10.	0.115	-0.120	0.135	-0.130	0.018	0.148	-0.376	0.095	-0.017	0.729	-0.238	-0.359	0.252	-0.266	0.206	-0.192	-0.390	0.097	-0.899	0.020	-0.232	2-418			
11.	-0.073	0.007	-0.043	0.109	-0.513	-0.625	0.400	-0.039	-0.383	-0.158	0.966	0.353	-0.031	0.069	-0.198	0.160	-1.112	-1.104	-0.093	-0.042	-0.724	-0.389	3-015		
12.	-0.235	0.065	-0.078	0.248	-0.381	-0.555	0.317	-0.076	-0.246	-0.430	0.288	1.083	-0.070	0.195	-0.239	0.114	-1.039	-1.475	-0.254	-0.734	-0.793	-0.625	0-450	4-471	

APPENDIX B

Covariance matrix of the value items for the Netherlands (N = 379). The first 12 variables represent the first wave and the second 12 variables represent the third wave.

	1974												1985															
	1	2	3	4	5	6	7	8	9	10	11	12	1	2	3	4	5	6	7	8	9	10	11	12				
1.	1.312																											
2.	-0.681	1.148																										
3.	-0.264	-0.318	1.262																									
4.	-0.366	-0.149	-0.680	1.195																								
5.	0.420	-0.326	0.047	-0.141	3.896																							
6.	0.610	-0.430	0.053	-0.233	0.208	3.072																						
7.	-0.931	0.683	0.102	0.147	-0.862	-1.082	4.333																					
8.	-0.221	0.113	0.058	0.050	-0.828	-0.770	-0.191	3.411																				
9.	0.184	-0.107	-0.288	0.211	0.037	-0.027	-0.783	-0.443	3.640																			
10.	0.828	-0.607	0.396	-0.617	0.232	0.826	-1.256	-0.078	-0.452	3.709																		
11.	-0.263	0.204	-0.184	0.242	-1.067	-0.860	-0.088	-0.344	-0.498	-1.405	3.889																	
12.	-0.617	0.347	-0.216	0.485	1.228	-0.975	0.044	-0.317	1.288	1.351	0.571	4.738																
1.	0.457	-0.341	0.130	-0.246	0.306	0.290	-0.680	-0.076	0.119	0.698	-0.301	-0.365	1.034															
2.	-0.333	0.332	-0.093	0.093	-0.146	-0.251	0.479	-0.023	0.008	-0.433	-0.016	0.300	-0.562	1.039														
3.	0.033	-0.161	0.317	-0.189	0.094	0.071	-0.069	0.040	-0.231	0.303	-0.021	-0.164	-0.147	-0.307	0.991													
4.	-0.158	0.170	-0.354	0.342	-0.255	-0.110	0.270	0.059	0.104	-0.568	0.338	0.230	-0.325	-0.170	-0.537	1.031												
5.	0.270	-0.188	0.252	-0.334	1.189	0.280	-0.323	-0.227	0.351	0.443	-1.058	-0.677	0.385	-0.250	0.277	-0.412	4.399											
6.	0.439	-0.349	-0.039	-0.050	0.058	1.473	-0.657	-0.341	0.342	0.547	-0.548	-0.746	0.322	-0.310	-0.003	-0.010	0.758	2.888										
7.	-0.675	0.490	-0.111	0.295	-0.544	-0.405	1.076	0.349	-0.295	-0.548	0.053	0.447	-0.819	0.721	-0.057	0.155	-0.887	-1.193	4.298									
8.	-0.126	-0.047	0.068	0.105	-0.394	-0.185	0.297	0.403	-0.203	-0.219	0.108	0.230	-0.066	0.061	0.031	-0.027	-0.679	-0.516	-0.159	2.475								
9.	0.210	0.063	-0.359	0.086	0.579	-0.184	-0.209	0.079	0.665	-0.178	-0.092	-0.560	0.228	-0.154	-0.209	0.136	-0.146	-0.215	-0.742	-0.209	3.350							
10.	0.804	-0.699	0.376	-0.481	0.415	0.264	-1.027	-0.012	-0.051	1.571	-0.644	-0.728	0.831	-0.543	0.222	-0.510	0.268	0.435	-1.365	-0.312	-0.359	3.189						
11.	-0.283	0.250	-0.233	0.266	-0.694	-0.511	0.281	-0.262	-0.111	-0.873	1.394	0.845	-0.292	-0.005	-0.209	0.506	-1.804	-1.029	-0.299	-0.260	-0.551	0.849	4.323					
12.	-0.619	0.462	0.039	0.118	-0.599	-0.687	0.523	-0.012	-0.714	-0.711	0.767	1.199	-0.576	0.460	-0.046	0.162	1.877	-1.095	0.325	-0.318	-1.118	-1.016	0.459	4.618				